



Industrial Building and Cold Storage Solutions

A new extended range of high-performance systems from the World leader



“Pioneering new technologies, creating sustainable building solutions and delivering award winning building design. This is what Kingspan Jindal is made of.”

Coldstore Facility, Sri Lanka

Contents

01

Introduction

Introducing Kingspan Jindal	
Our Products and Systems	
What is an Insulated Panel?	
Why Kingspan Jindal Insulated Panels?	

02

Panel Systems

4	Strupan Roof Panels	18
6	Isoclad Secret Fix Wall Panels	20
8	Coldwell Coldstore Panels	22
12	Mineral Wool Roof and Wall Panels	24
	Ultima Wall Panels	26
	KS1100 CTF Coldstore Panels	28
	Fabrications	30
	Finishes and Coatings	36
	Projects	38



Bravo Supermarket, Azerbaijan

Introducing Kingspan Jindal

The Kingspan Group is a global leader in the design, development and delivery of advanced building envelope products and solutions.

4.4

billion Euro turnover
in 2018

129

global manufacturing
facilities

14,000+

employees worldwide

Kingspan Jindal at a Glance

The Kingspan Jindal partnership brings together Industry leading innovation and building technology know-how to create new high performance building solutions for India, Bangladesh, Nepal, Bhutan, Maldives, Seychelles and Sri Lanka.

An expanded portfolio containing innovative and aesthetically stunning products and systems enables Kingspan Jindal to deliver a broader range of solutions for a wide variety of applications and building types.



This portfolio includes a wide range of products, parts of which are illustrated in this product selector.

“The way we build can be more effective and reach higher standards than ever before. We can make our buildings really work for us, consuming and generating energy smartly, and become real investments in our future.”

Gene M. Murtagh
Chief Executive Officer, Kingspan Group plc.

Insulated Panel Building Envelopes – Our Products and Systems



Daylighting & Smoke
Ventilation System

Insulated Wall
Panel System

Roof System

Facade



Services

We have a different way of working at Kingspan Jindal, we help our architects, installers and building owners realise their designs by being with them every step of the way, from concept to creation. When you choose Kingspan Jindal you don't just buy a product you get the support to keep projects running smoothly, as standard.

Kingspan Jindal specialise in full systems manufacture and supply, offering clients and designers a reliable, single-sourced supply for high-performance envelopes.

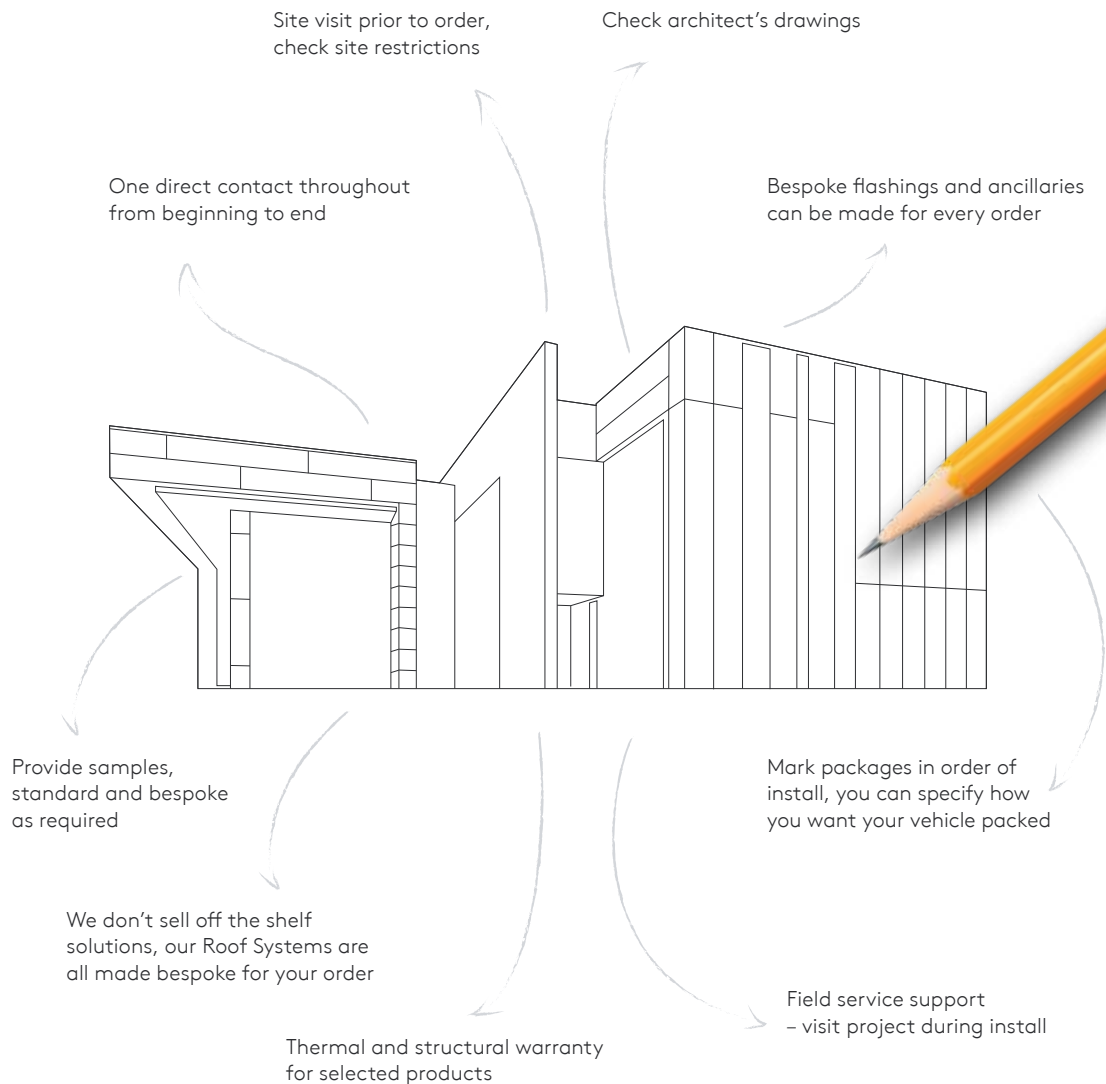

What is an Insulated Panel and what are the System Benefits?

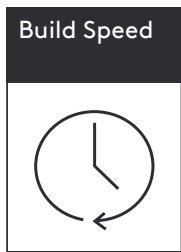

Kingspan Jindal panels are single component, factory pre-engineered systems. They are made up of rigid Polyurethane PUR, Polyisocyanurate PIR and IsoPhenic IPN insulation cores which are sandwiched between two layers of metal – one the external weather side, the other a pre-finished internal liner. The result is a single component solution that replaces multi-part construction.

Site-Assembled System

Exterior insulation and finish system (EIFS) multi-component systems.

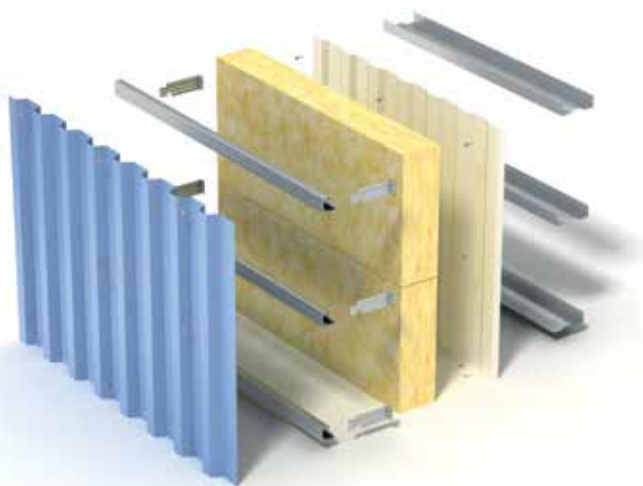

Built-up on-site system with multiple components from a large number of suppliers

Insulated Panel

Single-component system – factory-made thermal-insulation panel.





Building Systems Component Analysis

Assemblies with multiple components are more likely to experience delays in construction due to the scheduling of multiple trades, materials and site programmes.

These systems are prone to poor site assembly accuracy and can therefore be subject to interstitial condensation, early life failure, missing components and thermal insulation gaps and voids.

At the same time, guarantees, service support, site inspections and maintenance are also supplied by multiple sources which can lead to increased risk of liabilities.

Faster Build

Kingspan Jindal insulated roof and wall systems offer significant advantages over conventional site-assembled systems.

They provide a fast, single-fix installation with reliable thermal performance, insulation continuity, minimal air leakage and the elimination of interstitial cavity condensation and cold bridging.

Construction Schedule

Area – 9250 m³

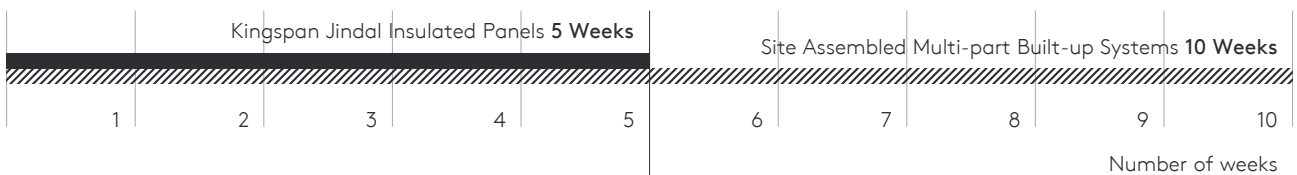

What is an Insulated Panel and what are the System Benefits?



The easiest, fastest and most cost-effective strategy to reduce heating and cooling energy demand and construction costs is to use Kingspan Jindal insulated wall and roof systems.

Choice of Insulation Core Technologies

- **PUR**
PUR is a popular, widely-used, insulation material. Like other light polymers with cell structure, the polyurethane has excellent thermal insulation properties.
- **IPN**
IPN is also a polymer but has a superior fire performance. It has a more rigid, closed cell structure created by a trimerization process and therefore offers better thermal performance.
- **Mineral Wool**
Mineral wool insulation is created from naturally occurring fibre with very high temperature resistance properties. It has exceptional fire performance and good tensile strength, making the panels strong and stable.

Superior U-values

Kingspan Jindal also offer FIREsafe and FIBREfree IPN insulation cores, uniquely designed in-house to guarantee a superior thermal performance in hot and cold climates. The panels are fitted to the exterior of the building and create a thermally insulated envelope, which reduces internal temperature loss and provides a thermal shield against external temperatures.

The closed cellular structure of the insulation provides zero moisture ingress with no air infiltration. This guarantees lifetime thermal reliability, without ageing or degradation.

FIREsafe™
FIBREfree

FIBREfree System

- Closed cell structure of the insulation:
 - zero moisture ingress;
 - no air infiltration; and
 - lifetime thermal reliability, without ageing or degradation
- No risk of toxic mould and bacteria growth
- No risk of buildings or employers liability insurance cover exclusion for presence of toxic mould
- No release of fugitive fibres into internal environments



Design Flexibility and Aesthetic Appeal

Kingspan Jindal's commercial and industrial wall and roof systems offer designers a comprehensive range of building solutions for vertical and horizontal wall applications and for flat and pitched roof applications. The wide range of fabrication accessories enables the creation of fully integrated, eye catching and unique architectural features.

Available in multiple profiles, finishes, colour options and cover widths, Kingspan Jindal insulated panels provide customised building design and creative freedom.

All our panels are easily integrated with traditional construction methods and building systems.

Guaranteed Airtightness and Weathertightness

One of the biggest sources of building heat loss or heat gain is due to air leakage i.e. 'leaking buildings'. The superior joints on our systems ensure that they remain both air and weathertight over the life of the building.

We guarantee:

- Insulation continuity with no gaps or missing insulation;
- Low energy usage and operating costs;
- Exceptional U-value compliance and reliability;
- Low CO₂ emissions;
- 3m³/hr/m² airtightness certainty at 50 Pa.

The excellent thermal performance of Kingspan Jindal insulated panels can result in energy savings of as much as 30% more than standard, cavity-based insulation systems (site-assembled systems).

Why Kingspan Jindal Insulated Panels?

Better lifetime building performance is assured with Kingspan Jindal's factory pre-engineered insulated panel systems. Kingspan Jindal is also pleased to introduce a new **FM approved** and market-leading range of panels featuring Kingspan's advanced IPN insulation core.

The Benefits of Kingspan Jindal IPN Cored Insulated Panels

Single Component

Accelerated build speed can reduce time on site

Durability

Lifetime performance

High Performance Insulation

High U-values / FIREsafe / FIBREfree

Exterior Metal Skin

Perfect weather barrier, corrosion protected and colour coated

Interior Metal Skin

Perfect vapour barrier, corrosion protected and colour coated

Airtight System

Guaranteed for the lifetime of the building

Coatings Superiority

Selection of aesthetic profiles and colours offering a superior architectural appearance

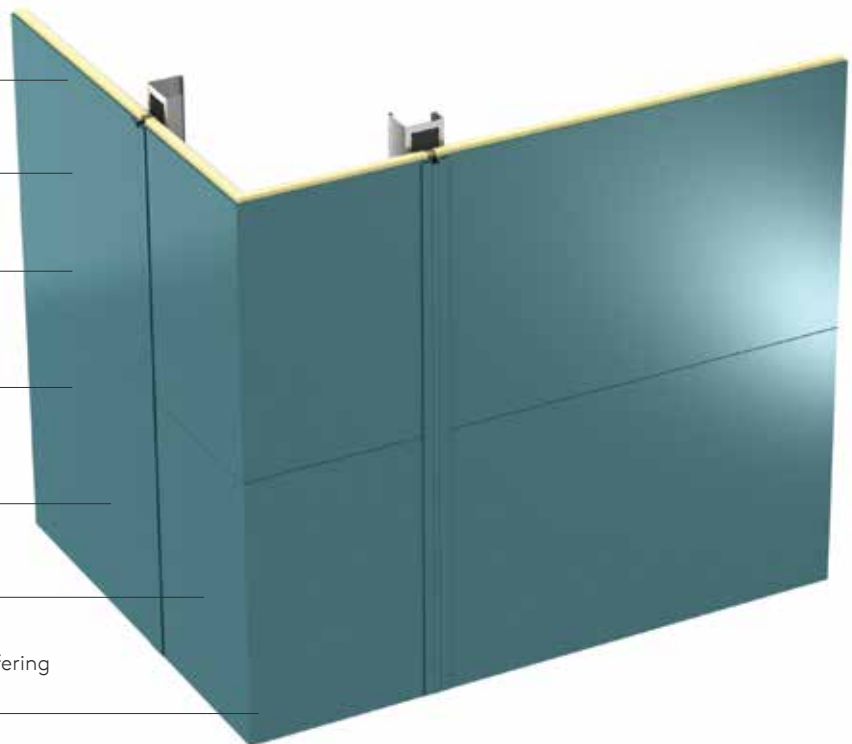

Additional benefits include:

- Superior thermal performance
- Structural capacity of Kingspan Jindal insulated panels
- Excellent vapour and weather resistant joints
- Internal washable surface options suitable for cleanroom, food preparation and hygiene applications
- Resistance to corrosion, termites and fungus
- CFC, HFC, HCFC free with zero ozone depletion potential
- Guarantee from Kingspan Jindal for system performance
- Superior technical service support from specification, product selection and contractor training
- Superior aesthetics
- High quality
- Colour range

Introducing IPN Insulated Panels – a New Horizon in Performance

IPN is a highly advanced insulation core, delivering all the benefits of closed cell insulation (superior energy-efficiency and fast, lightweight construction) with enhanced thermal and fire performance.

Superior Thermal Performance

Thermal transfer comparison assumes same thickness of insulation material.

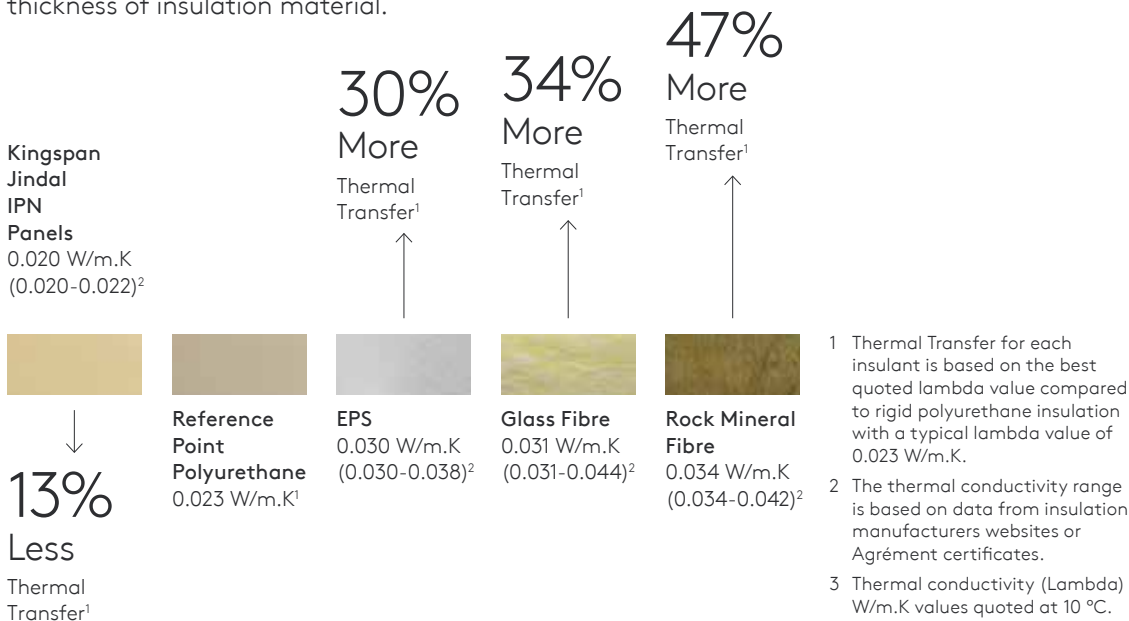

The unique, proprietary formulation of Kingspan Jindal's IPN insulation core ensures that IPN insulated panel systems meet the high performance requirements of large-scale insurance industry tests including FM 4880, 4881 and 4471.

Independently assessed real fire case studies have demonstrated that IPN insulated panel systems do not propagate fire, protecting people and property in fire scenarios.

The Kingspan Jindal Approach

Early planning of the building envelope makes sense. By adopting an energy saving strategy, buildings deliver an optimal insulation performance, superior airtightness and excellent moisture control. Buildings become more energy efficient and produce less carbon.

Our energy efficiency approach is a first step strategy for optimising a building's performance and beginning the route to achieving carbon neutrality. The building envelope and energy consumption must be central considerations in building design.

For arid and tropical climates this means:

- Low heat gain from external hot temperatures
- Consistent internal temperature
- Better efficiency of air-conditioning units
- Lower building cooling costs
- Reduced carbon footprint
- Protection against hot exterior temperatures
- More comfortable working environment for employees
- More efficient work output

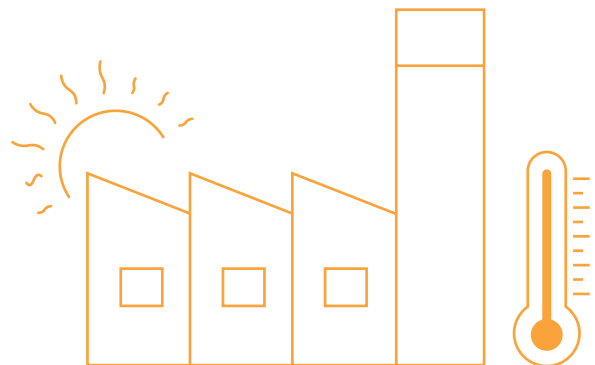

For temperate and cold climates this means:

- Low internal heating loss
- Consistent internal temperature
- Better efficiency of heating and cooling systems
- Lower costs for building temperature control
- A more sustainable building with lower carbon footprint
- Protection against cold exterior temperatures
- More comfortable working environment for employees



Assured Quality

Our products conform to international standards and ensure high performance. All Kingspan Jindal plants are ISO 9000 accredited and have standard operating procedures in place in order to produce and supply a high quality product to the customer.

All our products are tested for performance and reliability in accordance to established standards.

To maintain consistent quality, our entire plants run through a 400KVA UPS to have a stabilised power supply.

Some of the essential tests performed in our labs are:

- Thermal conductivity
- Dimensional stability
- Water vapour permeability
- Closed cell content
- Compression strength
- Adhesion strength
- Cross heater
- Horizontal burning

We are committed to offer complete customer satisfaction with cost effective products and services.



Insulated Panel Systems for Cold Storage and Industrial Buildings

Kingspan Jindal insulated panels are single component, factory pre-engineered systems that offer significant advantages over conventional site-assembled systems. They provide a fast, single-fix installation with high and durable thermal performance, insulation continuity, minimal air leakage and the elimination of interstitial cavity condensation and cold bridging.



Insulated Roof System Strupan



Strupan is an insulated roof panel with a trapezoidal profiled steel exterior and has outstanding structural rigidity and has a ribbed internal liner on the inside.

The standard thermal insulation core is high performance PUR and PIR with additional available options for even higher performance with Kingspan Jindal IPN and FM approved PIR.

Specification

Profile:	Insulated trapezoidal roof panel with 35 mm deep profile
Fixing Detail:	Mechanical fixing is through top of rib to structural supports
Metal Type:	Steel (galvanised or galvalume)
Finish / coating:	See page 36
Application:	Suitable for outer roofs having slope 1:15 (4°) or more or wall cladding
Lengths:	Standard Length up to 12 metres. Longer lengths available on request
Cover Width:	1000 mm
Seals:	Site applied weather and air seal

Benefits

- Rapid, single component, single-fix installation of up to 450 m² per day
- Comprises an insulated core with a steel top sheet and lower sheet
- Stable for walk on roofs for medium to heavy roof traffic as per design
- Can be easily integrated with skylight and other roof opening arrangements
- Can be easily integrated with roof top solar PV and fall arrest systems

Product Specifications and Accreditations

Product Reference	Standard Environment	Temp. Control	Hygiene	High Humidity	Low Temp	Fire Certification*
KJ1000 RW Strupan	✓	✓	✓	✓	•	✓



Product Profile

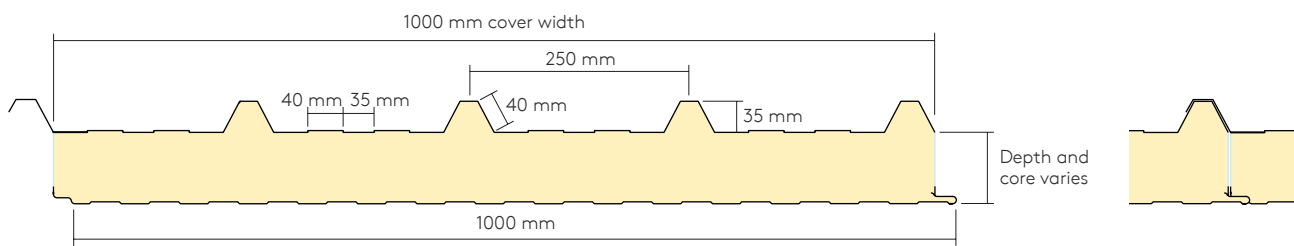

Dimensions, Weight and Thermal Performance

	KJ1000 RW Strupan							
Core Thickness (mm)	25	30	40	50	60	80	100	120
Overall Thickness (mm)	60	65	75	85	95	115	135	155
U-value (W/m ² K)	0.72	0.62	0.49	0.40	0.34	0.26	0.21	0.18
R-value (W/m ² K)	1.39	1.61	2.04	2.48	2.91	3.78	4.65	5.52
Weight (kg/m ²)	8.10	8.30	8.70	9.10	9.50	10.30	11.10	11.90

Above panel has external substrate of colour coated painted steel 0.45 mm thick and internal steel substrate 0.3 mm thick. Internal steel facing is painted white as standard in U-value has been calculated using the method required by the appropriate National Building Regulations.

*National Standard India.

Insulated Wall System Isoclad Secret Fix



Isoclad insulated panels feature a joint which hides the primary fasteners and renders the joint a secret fixing joint. They can be used in application on walls as well as facades and can be easily integrated with windows, doors, louvres, glazing and curtain walling.

Specification

Profile:	Architectural wall panel with lightly profiled surface offering a range of mini profiles
Fixing Detail:	Secret-fix appearance (hidden primary fasteners)
Metal Type:	Steel (galvanised or galvalume)
Finish / coating:	See page 36
Application:	Suitable for wall cladding, partitions and facades in vertical or horizontal layout formations
Lengths:	Standard Length up to 12 metres. Longer lengths available on request
Cover Width:	1000 mm
Seals:	Site applied weather and air seal

Benefits

- Better aesthetics as fixings are not visible
- Can be easily integrated with glazing, curtains, door, windows, etc
- Can be easily integrated with wall light and other wall opening arrangements
- Comprises an insulated core with a steel top sheet and lower sheet
- Suitable for horizontal or vertical applications

Product Specifications and Accreditations (based on Kingspan Jindal PUR/PIR insulation)

Product Reference	Standard Environment	Temp. Control	Hygiene	High Humidity	Low Temp	Fire Certification*
KJ1000 AWP Isoclad	✓	✓	✓	✓	•	✓



Waitrose Distribution, UK

Product Profile

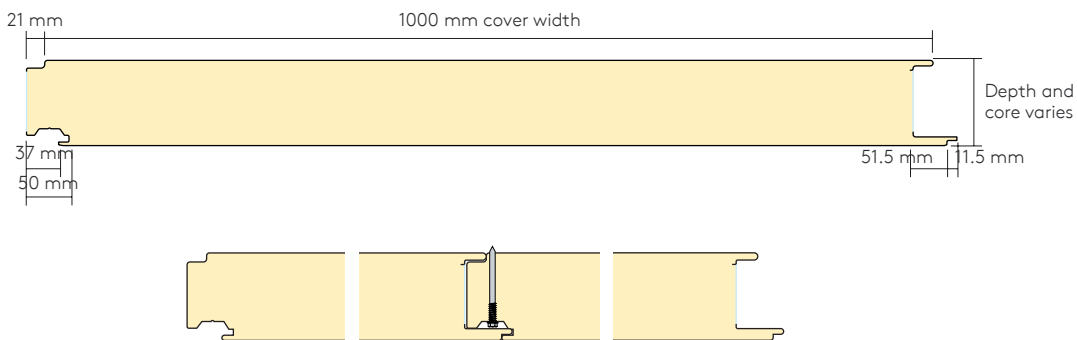

Dimensions, Weight and Thermal Performance (based on Kingspan Jindal PUR/PIR insulation)

	KJ1000 Isoclad					
Core Thickness (mm)	30	40	50	60	80	100
Overall Thickness (mm)	30	40	50	60	80	100
U-value (W/m ² K)	0.77	0.58	0.46	0.38	0.29	0.23
R-value (W/m ² K)	1.30	1.74	2.17	2.61	3.48	4.35
Weight (kg/m ²)	7.82	8.22	8.62	9.02	9.82	10.62

Above panel has external substrate of colour coated painted steel 0.45 mm thick and internal steel substrate 0.3 mm thick. Internal steel facing is painted white as standard in U-value has been calculated using the method required by the appropriate National Building Regulations.

*National Standard India.

Insulated Wall System Coldwell

Coldwell insulated panels are unique, tongue and groove joint panels suitable for airtight, panel to panel interlocking that is easy to install and provides an effective seal. Coldwell panels offer a higher thickness of insulation core and are self supporting up to 15 meters.

They form a range of high performance insulated panel systems that have been specifically designed for use within temperature controlled environments, cleanrooms and walk-in coldrooms.

The standard thermal insulation core is high performance PUR and PIR, with additional available options for even higher performance with Kingspan Jindal IPN and FM approved PIR.



Specification

Profile:	Insulated panel with tongue and groove joints
Fixing Detail:	Tongue and groove interlocking and sealed joints
Metal Type:	Steel (galvanised or galvalume)
Finish / coating:	See page 36
Application:	Suitable for partitions, walls and ceilings (can also be used as a Karrier system for facades)
Lengths:	Standard Length up to 15 metres. Longer lengths available on request
Cover Width:	1000 mm
Seals:	Site applied weather and air seal

Benefits

- Suitable for internal partitions, walls and ceilings
- Available in lengths of up to 15 metres
- Comprises an insulated core with a steel top sheet and lower sheet
- Can be easily integrated with curtains, door, windows, etc
- Can be easily integrated with other wall opening arrangements
- Superior thermal performance

Product Specifications and Accreditations (based on Kingspan Jindal PUR/PIR insulation)

Product Reference	Standard Environment	Temp. Control	Hygiene	High Humidity	Low Temp	Fire Certification*
KJ1020 CS Coldwell 1 & 2	✓	✓	✓	✓	✓	✓



Rand Logistics, UK

Product Profile

KJ1020 CS Coldwell 1

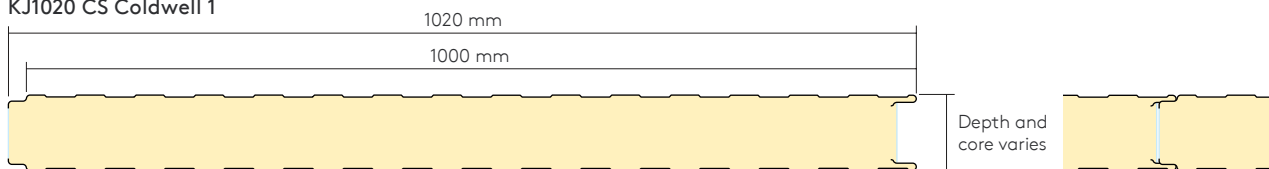

KJ1020 CS Coldwell 2

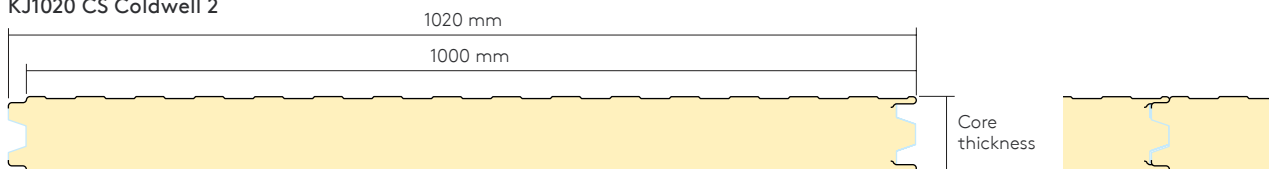

Dimensions, Weight and Thermal Performance (based on Kingspan Jindal PUR/PIR insulation)

	KJ1020 CS Coldwell 1						KJ1020 CS Coldwell 2			
Core Thickness (mm)	30	40	50	60	80	100	80	100	120	150
Overall Thickness (mm)	30	40	50	60	80	100	80	100	120	150
U-value (W/m ² K)	0.77	0.58	0.46	0.38	0.29	0.23	0.29	0.23	0.19	0.15
R-value (W/m ² K)	1.30	1.74	2.17	2.61	3.48	4.35	3.48	4.35	5.22	6.52
Weight (kg/m ²)	7.47	7.87	8.27	8.67	9.47	10.27	9.47	10.27	11.07	12.27

Above panel has external substrate of colour coated painted steel 0.45 mm thick and internal steel substrate 0.3 mm thick. Internal steel facing is painted white as standard in U-value has been calculated using the method required by the appropriate National Building Regulations.

*National Standard India.

Insulated Roof and Wall System Mineral Wool

Mineral fibre insulated panels are part of our diverse insulated panel range.

Mineral fibre panels are available in trapezoidal profile for the roofing solution and plain unprofiled for wall cladding applications.

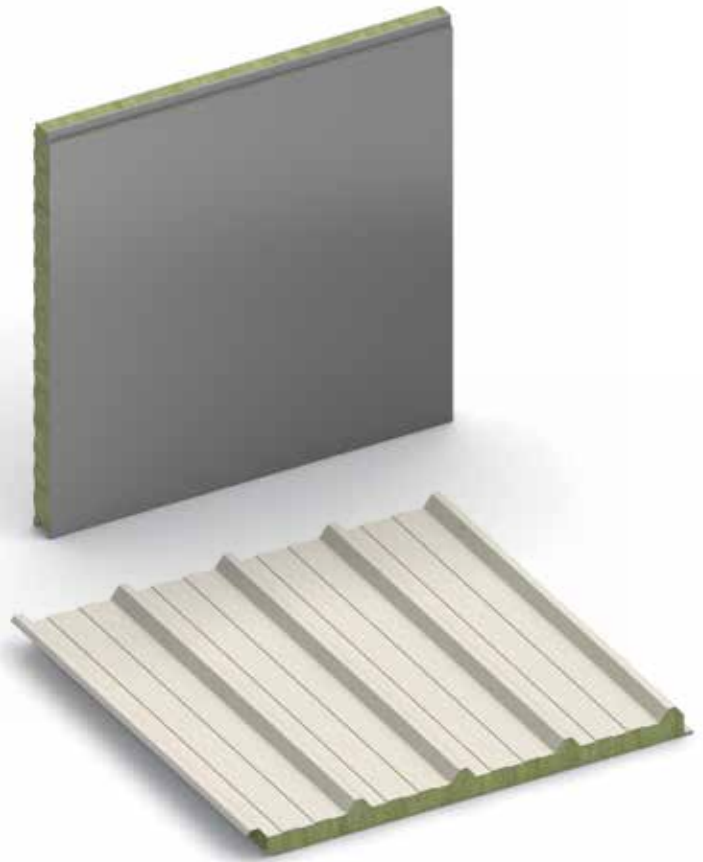

Specification

Profile:	Insulated trapezoidal roof panel with 35 mm deep profile. Insulated wall panel with tongue and groove fixing provision
Fixing Detail:	Tongue and groove fixing with mechanical fixing with structure support from outer sheet. Mechanical fixing is through top of rib to structural supports
Metal Type:	Steel (galvanised or galvalume)
Finish / coating:	See page 36
Application:	Suitable for roofs, partitions, façades, ceilings and cladding
Lengths:	Transportable lengths limited to 12 metres
Cover Width:	1000 mm
Seals:	Site applied weather and air seal

Benefits

- Faster installation of up to 450 m² per day
- Suitable for the roofs with slope of 1:15 (4°) or more
- Comprises an insulated core of mineral fibre slab with a steel top sheet and a steel lower sheet
- Stable for walk on roofs at medium to heavy roof traffic as per design
- Can be easily integrated with skylight, roof opening arrangements, solar panels, fall arrest systems, glazing, curtains, door, windows and skylights

Product Specifications and Accreditations (based on Jinroc mineral fibre)

Product Reference	Standard Environment	Temp. Control	Hygiene	High Humidity	Low Temp	Fire Certification*
Jinroc Roof & Wall	✓	✓	✓	✓	✓	✓



Adani Mundra, India

Product Profile

Jinroc Roof

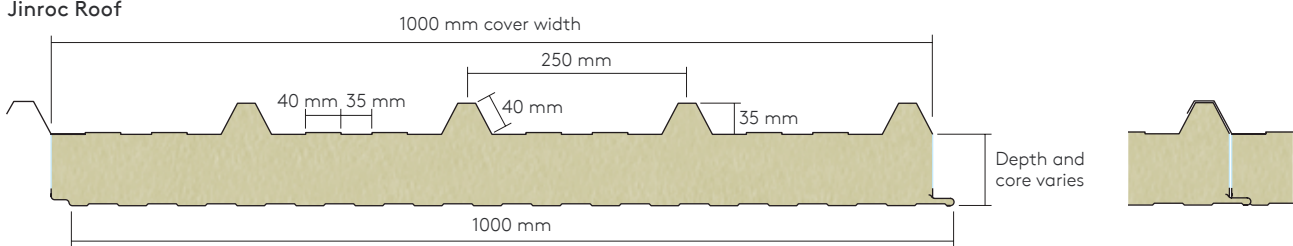

Jinroc Wall



Dimensions, Weight and Thermal Performance (based on Jinroc mineral fibre)

	Kingspan Jindal Jinroc Roof Panels						Kingspan Jindal Jinroc Wall Panels					
	50	60	80	100	120	150	50	60	80	100	120	150
Core Thickness (mm)	50	60	80	100	120	150	50	60	80	100	120	150
Overall Thickness (mm)	85	95	115	135	155	185	51-52	61-62	81-82	101-102	121-122	151-152
U-value (W/m ² K)	0.70	0.60	0.46	0.37	0.31	0.25	0.80	0.67	0.50	0.40	0.33	0.27
R-value (W/m ² K)	1.43	1.68	2.18	2.68	3.18	3.93	1.25	1.50	2.00	2.50	3.00	3.75
Weight (kg/m ²)	14.67	15.67	17.67	19.67	21.67	24.67	13.36	14.36	16.36	18.36	20.36	23.36

Kingspan Jindal Mineral Fibre Strupan Roof and Wall panels with 0.5 mm thick steel on both sides.
U-value has been calculated using the method required by the appropriate National Building Regulations.
*National Standard India.

Insulated Wall System Ultima



Ultima insulated panels are used for walls, partitions, soffits and ceilings. They uniquely feature the Camlock joint, this feature permits each panel to be tightly locked together to achieve very tight, air-sealed and hygienically clean joints.

Specification

Profile:	Insulated panel with cam-lock fixing arrangement
Fixing Detail:	Camlock fixing with mechanical fixing with structural support from outer sheet
Metal Type:	Steel (galvanised or galvalume)
Finish / coating:	See page 36
Application:	Suitable for partitions, façades and ceilings
Lengths:	Up to 6 metres
Cover Width:	From 150 mm to 1180 mm
Seals:	Site applied weather and air seal

Benefits

- Comprises an insulated core with a steel top sheet and a steel lower sheet
- Can be easily integrated with glazing, doors, windows and other wall opening arrangements
- Can be customized for minimizing the wastage
- Provision can be made to concealed wiring / conduiting
- Localized reinforcement can be provided as per the requirement

Product Specifications and Accreditations

Product Reference	Standard Environment	Temp. Control	Hygiene	High Humidity	Low Temp	Fire Certification*
KJ 1000 Ultima	✓	✓	✓	✓	✓	✓



Nagel Langdons Distribution Centre, UK

Product Profile

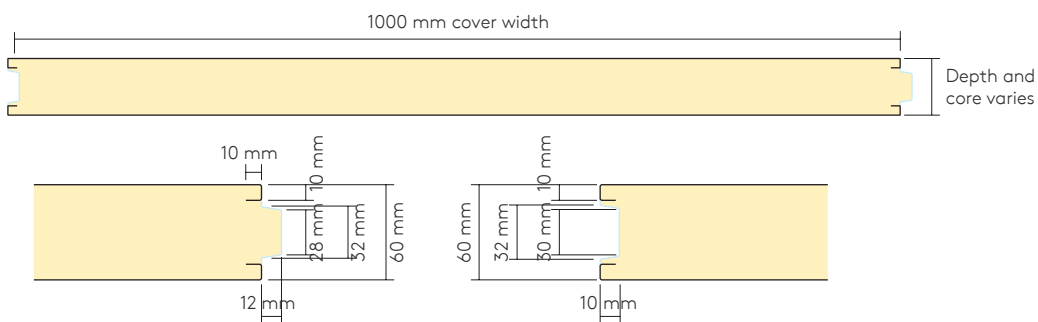

Dimensions, Weight and Thermal Performance

	KJ1000 Ultima			
Core Thickness (mm)	40	50	60	80
Overall Thickness (mm)	40	50	60	80
U-value (W/m ² K)	0.50	0.40	0.33	0.25
R-value (W/m ² K)	2.00	2.50	3.03	4.00
Weight (kg/m ²)	9.70	10.07	10.36	11.15

U-value has been calculated using the method required by the appropriate National Building Regulations.
*National Standard India.

FM Approved Cold Storage System KS1100 CTF



The KS1100 CTF is a wall and ceiling insulated panel system which is suitable for all types of buildings where there are low internal temperature conditions.

Kinspan Jindal Controlled Environment panels are designed for use within temperature controlled and hygiene safe environments, such as food processing, freezers, pharmaceutical, cold / chill store and cleanrooms.

These FIREsafe, hygienic and FIBREfree insulated panel systems are suitable for internal and external walls and ceilings, including internal 'box-within-a-box' applications.

The innovative joint system is designed to withstand high pressure washing and regular cleaning; preventing water ingress and minimising potential bacteria growth.

Product Features

Profile:	Izocold, Pharmacold, Microcold, Megacold
Metal Type:	Steel / stainless steel
Finish / coating:	See page 36
Application:	Suitable for internal and external roofs, walls and ceilings including internal 'box within a box' applications. Designed for installations with temperature range from -40 °C to ambient
Lengths:	From 2 m to 11.9 m*
Cover Width:	1100 mm
Fire Rating:	KS110 CTF Izocold, Pharmacold, Microcold, Megacold and Lockpanel are FM approved. KS110 CTF Izocold, Pharmacold, Microcold and Megacold are LPCB approved for 150 mm and 200 mm thicknesses

*11.9 m for container transport, 13.5 m for truck.

Benefits

- Designed to withstand internal / external temperature differences of up to 80 °C
- Suitable for cold and chill stores and food processing applications, with an internal temperature range of -50 °C to + 60 °C
- Suitable for internal and external applications including mushroom growing, data centres, partition walls, agricultural and controlled atmospheres
- Incorporates a panel joint that achieves excellent thermal performance and can accommodate vapour and hygiene safe seals
- Hygiene safe, resisting moisture ingress and any risk of toxic mould and bacterial growth

Product Specifications and Accreditations

Product Reference	Standard Environment	Temp. Control	Hygiene	High Humidity	Low Temp	Fire Certification
KS1100 CTF (except Smartpanel)	✓	✓	✓	✓	✓	✓

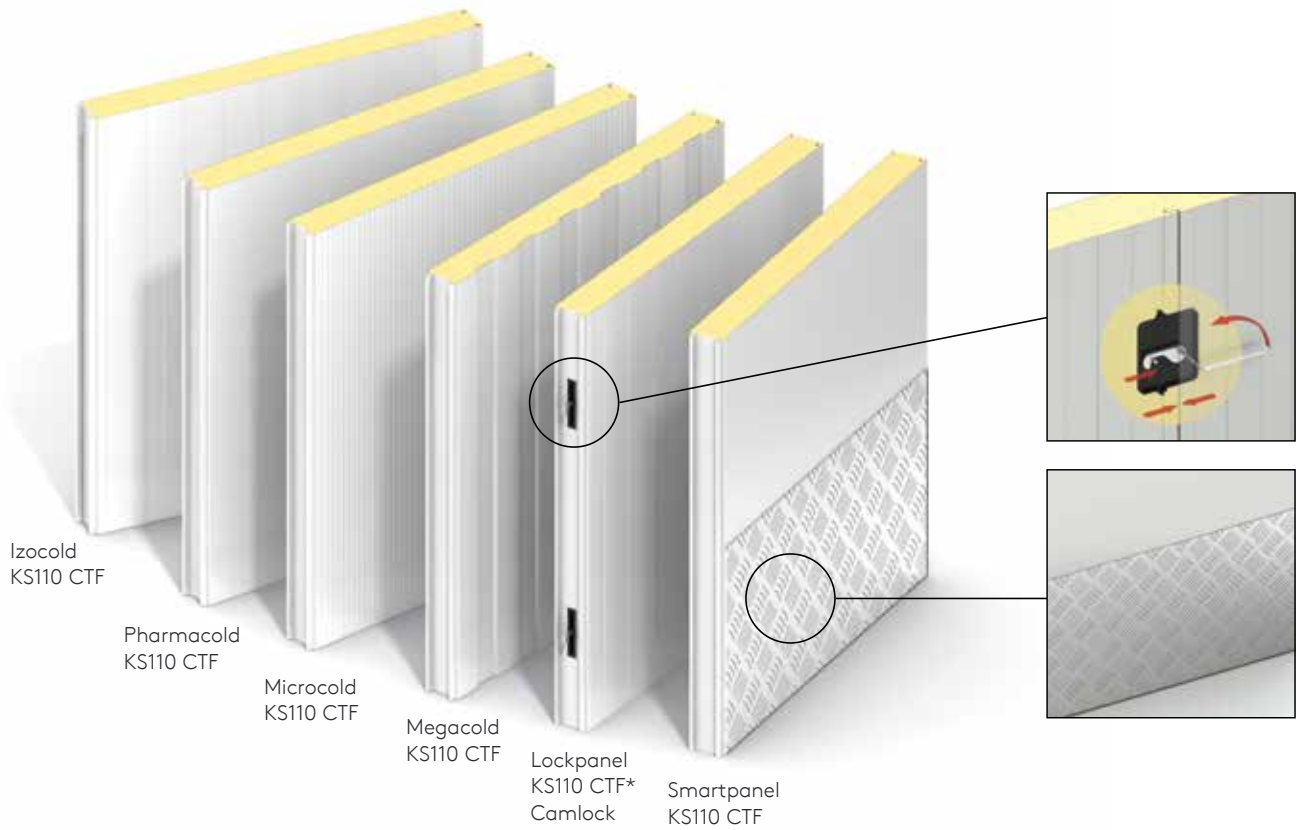

Product Profile

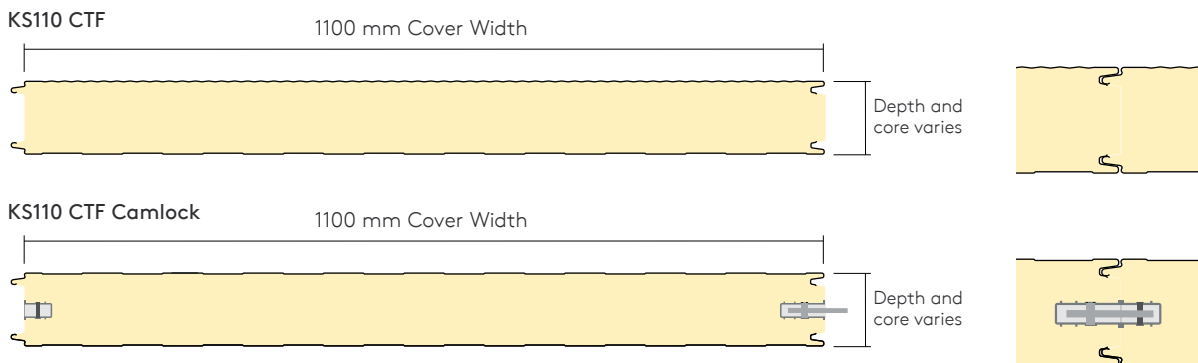

Dimensions, Weight and Thermal Performance

	KJ1100 CTF									
Core Thickness (mm)	40**	45**	60**	80	100	120	140†	150	170†	200
Overall Thickness (mm)	50	44	33	25	20	17	14	13	12	10
U-value (W/m²K)	0.50	0.44	0.33	0.25	0.20	0.17	0.14	0.13	0.12	0.10
R-value (W/m²K)	2.00	2.27	3.03	4.00	5.00	5.88	7.14	7.69	8.33	10.00
Weight (kg/m²) 0,5 steel / 0,5 steel (KS110 CTF)	11.03	11.26	11.69	12.53	13.36	14.20	15.04	15.45	16.29	17.54
Weight (kg/m²) 0,5 steel / 0,5 steel (KS110 CTF Camlock)	-	-	-	12.53	13.36	14.20	-	15.45	16.25	17.54

U-value has been calculated using the method required by the appropriate National Building Regulations.

* Available with Camlocks.

** KS110 CTF Megacold and KS110 CTF Camlock not available in these panel thicknesses.

† KS110 CTF Camlock not available in this panel thickness.

Wall Systems Fabrications Top Hats

We manufacture a range of bespoke top hats designed to complement our insulated wall panel systems. Our top hats provide solutions for vertical and horizontal applications, and steel top hats are available in standard or slimline dimensions to meet individual design requirements.

Product Compatibility

Top hats are available for Kingspan Jindal Isoclad Secret Fix Wall Panels. All top hats are suitable for vertical applications, whilst our aluminium raised cap and rubber gasket options are also suited to horizontal applications. Dimensions will vary depending on the panel specification, please contact our Technical Services Department for further information.

Available Lengths

Top hats are available in lengths up to 6 m. For further information, please contact our Technical Services Department.

Product Specific Benefits

- Manufactured from high-quality steel and aluminium
- Available in lengths up to 6 m
- Standard pre-cut finishes include Kingspan Jindal XL Forté, Kingspan Jindal Spectrum, Kingspan Jindal Altaris and Kingspan Jindal Polyester
- Polyester powder coating (PPC) finishes are available
- Compatible with the majority of the range of Kingspan Jindal insulated wall panels

Compatibility with Insulated Wall Panels (Laid Horizontally)

Material	Description / Options	Isoclad Wall Panels	Strupan Roof / Wall Panels
Steel	With no insert	✓	✓
	Fitted with a recessed or flush steel insert	✓	✓
Steel	Slimline top hat available with no insert, a flush or recessed insert, or fitted with a rubber gasket infill	✓	•
Steel	Raised feature detail	✓	•
Aluminium	Extruded top hat with a recessed aluminium insert	✓	•
	Fitted with a flush aluminium insert or a rubber gasket infill	✓	•
Aluminium	Picture frame effect with raised vertical and horizontal aluminium joint caps	✓	•
EPDM Rubber	Bi-modular effect with vertical and horizontal rubber gasket infills	•	•

* Standard steel top hats shown above are for Isoclad wall insulated panels. Top hats for Strupan trapezoidal wall insulated panels are slightly different in design and dimensions. Please contact our Technical Services department for panel-specific information.



Recessed Insert (standard)*

Flush Insert (standard)*

No Insert (standard)*

Raised

No Insert (slimline)

Recessed Insert (slimline)

Flush Insert (slimline)

Rubber Gasket (slimline)

Aluminium Extruded Profiles

EPDM Rubber Profile



Option D



Option E



Rubber Insert
Option F



Upstand
Capping



Rubber
Gaskets

Wall Systems Fabrications Preformed Corners

Our range of insulated preformed corners combine insulation continuity with aesthetic design to offer an alternative solution to traditional corner flashings. Preformed corners are essential to completing the overall architectural finish of a building, and our range offers a wide choice of bespoke products to suit individual project needs.

Options include:

- Single-cranked / mitred;
- Double-cranked / mitred (including chamfered and Z-shaped);
- Triple-cranked / mitred (including column encasements); and
- Curved.

Product Compatibility

Our preformed corners can be curved, cranked or mitred vertically and horizontally, as well as internally and externally, to achieve a truly bespoke solution.

Available Lengths

Minimum and maximum lengths, angles and radii will apply depending on the type of corner specified. For more information, please contact our Technical Services Department.

Product Specific Benefits

- Provide smooth panel joints for a superior architectural finish whilst maintaining insulation continuity with the wall panels.
- Offer a more aesthetically pleasing alternative to flashings.
- Compatible with the entire range of Kingspan Jindal insulated wall panels and available in the same colour options.
- Can be applied on the vertical or the horizontal of the insulated panel.



Round corner



Cranked corner



Double cranked corner



Angled corner



Z-shaped corner

Wall Systems Fabrications Flashings

From simple functional flashings to attractive aerofoil eaves fascia panels, our range combines functionality, performance and true aesthetics to provide the finishing touch to any building envelope.

With a wide selection of materials, gauges and finishes available, the possibilities for fabricated flashings are endless. Material options include pre-coated steel, galvanised steel and aluminium combined with a selection of insulated backings. A large range is held in stock to facilitate immediate supply.

Available Lengths

Flashings are available in lengths up to 8 m as standard. For longer lengths, or further information, please contact our Technical Services Department.

Product Specific Benefits

- Bullnose, corner, drip, ridge and verge profiles are available
- Curved smoothly or precisely folded to suit any application
- Secret-fix joint details are also offered, providing clean uninterrupted lines
- Available in lengths up to 8 m
- Manufactured from high-quality steel and aluminium. Other materials are available upon request
- A range of gauges are provided, including 0.5 mm to 0.9 mm (pre-coated steel), 0.7 mm to 3 mm (galvanised steel) and 0.9 mm to 4 mm (aluminium)
- Standard pre-coat finishes include Kingspan Jindal XL Forté, Kingspan Jindal Spectrum, Kingspan Jindal Altaris and Kingspan Jindal Polyester
- Polyester powder coating (PPC) finishes also available
- PVC / TPE membrane-lined fabricated ancillary components are also available, to complement our Topdek insulated roof panels



Verge
flashing



Bullnose
corner



Drip
flashing



Parapet
flashing

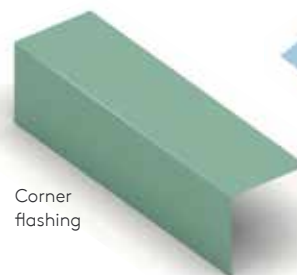

Corner
flashing



Ridge
flashing

Wall Systems Fabrications Specialist Fabrications

From aperture units to wall panel louvres, all of our specialist fabrication products are custom designed to suit individual project needs.

The range includes:

- Aperture units and ventilators;
- Soffits, verges and fascias;
- Bullnoses and feature details;
- Plank profiles;
- Box, integrated and dummy louvres.



Roof Systems Fabrications Gutters

Our extensive experience in fabrication techniques, combined with state-of-the-art production equipment, enables us to create eye-catching and unique architectural features.

From aperture vents and reveals, including window pods and service penetrations, to insulated guttering, all our products are custom designed and fabricated for each project – in various colours, module sizes and shapes.

Membrane Lined Insulated Gutter

Our membrane lined insulated gutter is suitable for both boundary wall and valley-hip gutter applications. It is available in lengths up to 8 m maximum, making it fast to install.

For any additional information, please contact us. The system incorporates a closed-cell PUR, PIR or FM approved IPN insulation core. It is fully tested and provides U-values of 0.31 W/m²K and 0.20 W/m²K for 60 mm and 100 mm thicknesses respectively.

Gutter components to complete the system, including internal and external corners, stop ends, T-sections, sumps, overflows, soakers, weirs and downpipes are available to order.

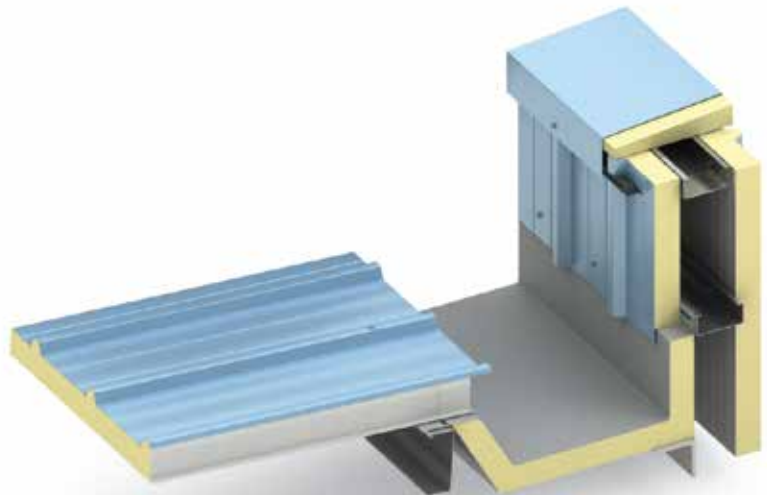

Highline Gutters

Lightweight pre-coated steel guttering is available in lengths up to 8 m and is supplied in a corrosion-resistant range of finishes.

Downpipes, brackets and accessories, including unique architectural hopper boxes, are also available to complete our gutter system.



Gutter Design Software

We provide a full gutter design package specifying all technical data to confirm that the gutter is of a functional design.

Finishes and Coatings

Kingspan Jindal Insulated Panels uses prepainted coloured metals in the manufacture of highly efficient insulated panels.

There are four options of thermal insulation available from Kingspan Jindal. The standard thermal insulation core is PUR and PIR and Mineral Wool but IPN, FM Approved PIR thermal insulation are also available. All core options can be sandwiched between two layers of metal – the external weather side and the pre-finished internal liner.

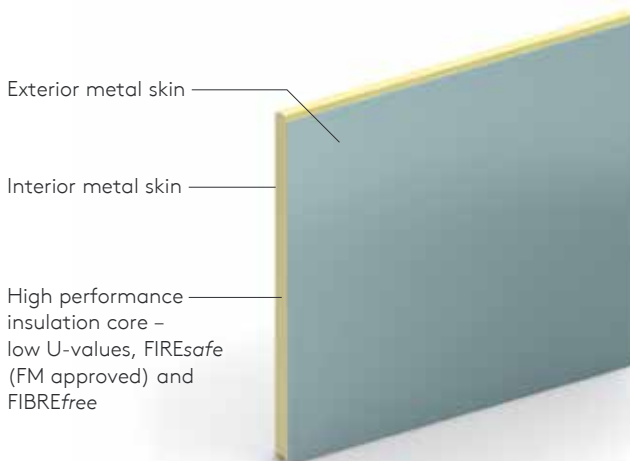

Prepainted coloured metals are manufactured under strict quality control in the coil coating process. Metal coils are most commonly coated with a liquid paint by roller-coating; other technologies include a pre-formed film laminated to the coil surface or a powder paint applied on top of it. Steel and aluminium are the most common metal substrates for prepainting.

Prepainted coloured metals are often considered more durable and more corrosion-resistant than most post-painted metals because the metal is treated before it is cut and formed, and the entire surface is cleaned and treated, providing tightly-bonded finishes.

The choice of prepainted coloured metal is fundamental as both the exterior and the interior metal skins play a critical role in defining the insulated panel performance, durability and appearance.

Selecting the right coating can be a challenging task.

The requirements for a prepainted coloured metal product are defined by the end use to which it will be put, so before choosing a product it is worthwhile to answer a number of questions:

- Which environment is the insulated panel destined for; external or internal?
- How long is the insulated panel required to last?
- What elements will it be exposed to throughout its lifetime; UV radiation, rain, sea salt spray, pollutants, chemicals?
- Are there any specific temperature / humidity / chemical corrosion resistance requirements?
- Will the insulated panel need to demonstrate superior resistance to scratching or indentation either in the manufacturing process or in the final application?
- What finish is required; smoothness, gloss, texture and colour?

Answering as many of these questions as possible will determine what coating properties are important and what prepainted coloured metals are suitable.

Kingspan Jindal offers the following coating systems:

External Applications

- Kingspan Jindal Polyester
- Kingspan Jindal Spectrum (polyurethane)
- Kingspan Jindal Altaris (PVDF)
- Kingspan Jindal XL Forté (PVC)

Special Applications

- Kingspan Jindal AQUAsafe 55

Internal Applications

- Kingspan Jindal CLEANsafe 15
- Kingspan Jindal CLEANsafe 25
- Kingspan Jindal CLEANsafe 55
- Kingspan Jindal CLEANsafe 120
- Kingspan Jindal CLEANsafe 304*

* Stainless steel, non-coloured coatings

Extra reassurance where you need it:



✓ Corrosion



✓ UV



✓ Chemical



✓ Condensation

Kingspan Jindal coatings offer many important advantages over those provided by any other manufacturer in the market:

- **Excellent corrosion resistance**
Kingspan Jindal coatings are best in class for corrosion resistance. They use innovative metal alloy substrates, which provide maximum resistance to corrosion from scratches and on cut edges.
- **Advanced colour stability and UV resistance**
Kingspan Jindal coatings use state-of-the-art thermoplastic paint technology with improved UV resistance, better gloss retention and weather resistance.
- **Environmentally safe**
Our coatings have been designed in accordance with Kingspan Jindal's sustainable development policy. They are phthalate-free, contain no heavy metals and are fully recyclable. Phthalate-free chemistry contributes to maintaining a safe and healthy environment.
- **Maintenance-free, saving time, trouble and cost**
Kingspan Jindal coatings do not require any special maintenance regime and their performance will not deteriorate during their lifetime.
- **Meeting individual needs**
The range of Kingspan Jindal coatings is designed to offer a choice of specifications and guarantees to meet the needs of every application. Whatever the technical, environmental or budget requirements, the Kingspan Jindal range of coatings offers the ultimate solution.
- **Guarantee**
Kingspan Jindal offers a unique Guarantee Package that includes a coating guarantee against corrosion, chemical attack, UV rays, humidity and abrasion for up to 40 years (in nominated geographic zones), so the building owner can be sure that the building will continue to look good year on year.

Kingspan Jindal offers the following range of coating systems suitable for external applications:

- Kingspan Jindal Polyester
- Kingspan Jindal Spectrum (polyurethane)
- Kingspan Jindal Altaris (PVDF)
- Kingspan Jindal XL Forté (PVC)

Projects

Commonwealth Games
Delhi



Adani Mundra Ltd
Gujarat



TCI Ltd
Manesar Haryana



VKNRL School
of Nursing
Assam





Agro Merchants Group
The Netherlands



RAND Logistics
Australia



Dabur India Ltd
Assam



Madhusilica Ltd
Gujarat

Kingspan Jindal Pvt. Ltd.

Old Manesar Road
Narsinghpur
Gurgaon - 122001
Haryana
India

t: +91 124 4393 200
e: sales@kingspanjindal.com

Kingspan Jindal is a member company
of the Kingspan Group.



kingspanjindal.com